

hurricane pumps

Motors up to 9.2 kW

Hurricane Pumps

Certikin's 'Hurricane' pump range offers all the power and performance of a traditional cast iron centrifugal pump with the added versatility of a chemically resistant, lightweight modern plastic design.

Capable of pumping large volumes of water at high pressure, Hurricane pumps are supplied with 3-phase motors starting at 2.9 kW (4.0HP) through to 9.2 kW (12.5HP), achieving flows in excess of 150m³/hr

- Flooded suction.
- Suitable for salt water applications.
- Available with or without pre-filters.
- Quick fit union connections.
- Plastic composite body.
- 316 stainless steel shaft.
- Plastic impellor on 4.0HP and 5.5HP models.
- Bronze impellor on 7.5HP, 10HP and 12.5HP models.
- 316 stainless steel strainer basket (Pre-filter models).
- IP55 protection rated.
- Max. water temperature 40°C.



Performance Data - Certikin Hurricane Commercial Pumps - With Pre-Filter

Code	Phase	Description	Running Current	Head (m)									
				6	8	10	12	14	16	18	20	10	
				Flow m ³ /hr									
CP400S	3	4.0HP (2.9kW)	6.9 AMP	96	84	72	58	36	-	-	-	-	-
CP550S	3	5.5HP (4.0kW)	9.4 AMP	116	96	84	68	46	-	-	-	-	-
CP750S	3	7.5HP (5.5kW)	12.1 AMP	-	126	114	100	88	68	44	-	-	-
CP1000S	3	10HP (7.4kW)	16.0 AMP	-	140	130	118	105	92	72	48	-	-
CP1250S	3	12.5HP (9.2kW)	21.2 AMP	-	157	148	136	122	104	84	64	30	-



Performance Data - Certikin Hurricane Commercial Pumps - Without Pre-Filter

Code	Phase	Description	Running Current	Head (m)									
				6	8	10	12	14	16	18	20	22	
				Flow m ³ /hr									
CP400B	3	4.0HP (2.9kW)	6.9 AMP	102	90	74	62	38	-	-	-	-	-
CP550B	3	5.5HP (4.0kW)	9.4 AMP	120	104	88	70	48	-	-	-	-	-
CP750B	3	7.5HP (5.5kW)	12.1 AMP	-	132	120	104	90	72	50	-	-	-
CP1000B	3	10HP (7.4kW)	16.0 AMP	-	148	136	122	110	98	80	52	-	-
CP1250B	3	12.5HP (9.2kW)	21.2 AMP	-	168	154	142	126	112	90	66	32	-

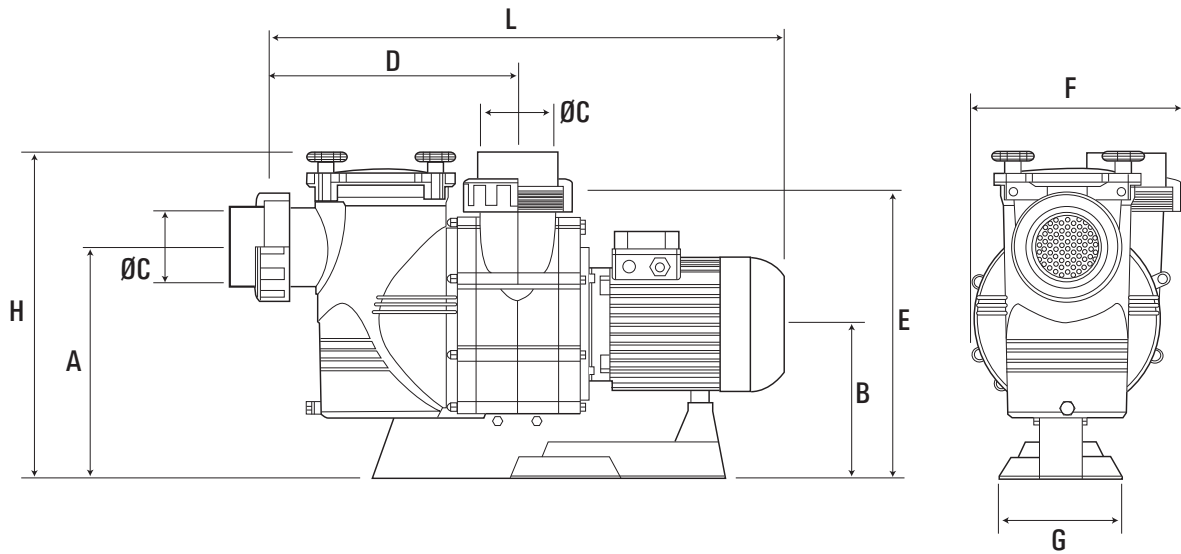

Dimensions With Pre-Filter

Code	Model	A	B	ØC	D	E	F	G	H	L	Weight
CP400S	4 HP	375	255	90	115	470	330	200	535	820	48
CP550S	5.5HP	375	255	110	115	470	330	200	535	840	52
CP750S	7.5HP	375	255	110	115	470	330	200	535	840	57
CP1000S	10.0HP	375	255	110	115	470	330	200	535	910	68
CP1250S	12.5P	375	255	110	115	470	330	200	535	955	72

Design improvements may invalidate the dimensions. Latest drawings are available on request

- All dimensions are in mm
- All weights shown are in kg

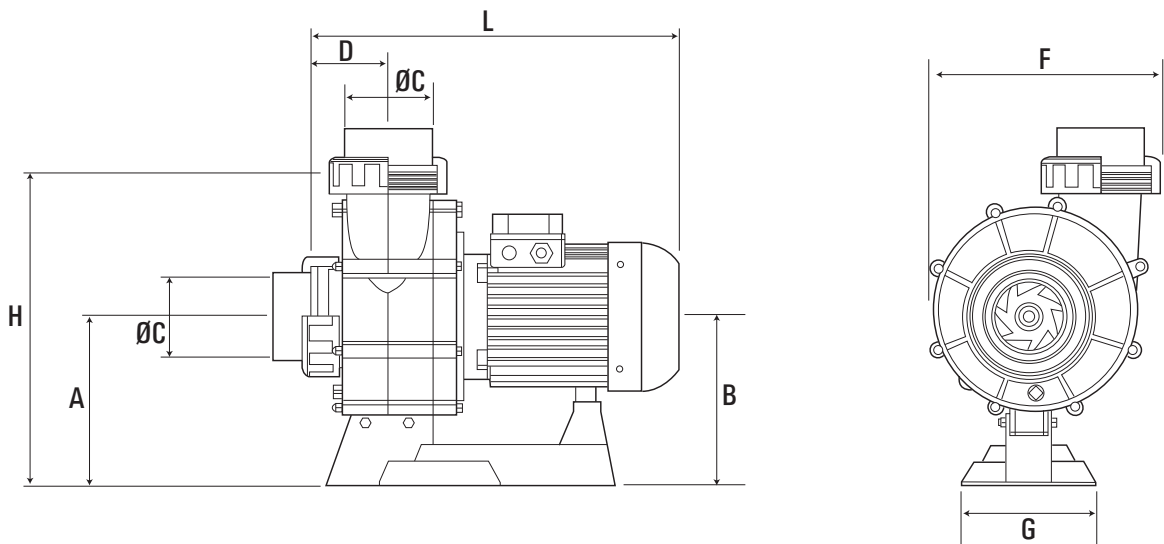

Dimensions Without Pre-Filter

Code	Model	A	B	ØC	D	E	F	G	H	L	Weight
CP400B	4 HP	255	255	90	115	?	330	200	470	510	41
CP550B	5.5HP	255	255	110	115	?	330	200	470	530	44
CP750B	7.5HP	255	255	110	115	?	330	200	470	530	50
CP1000B	10.0HP	255	255	110	115	?	330	200	470	600	61
CP1250B	12.5P	255	255	110	115	?	330	200	470	645	65

heavy duty edition 3